

DEUTSCH	3
ENGLISCH	14
FRANÇAIS	25
ITALIANO	36

BETRIEBSANLEITUNG UND SICHERHEITSVORSCHRIFTEN
OPERATING AND SAFETY INSTRUCTIONS
MODE D'EMPLOI ET DE SÉCURITÉ
ISTRUZIONI PER L'USO E DI SICUREZZA

OR-T 50

Ab Serie-Nr. 50/61650

From serie no 50/61650

A partir du no de série 50/61650

A partire dal no di serie 50/61650

Handgerät zum Umreifen mit Kunststoffband

Hand tool for plastic strapping

Appareil pour cerclage par bande plastique

Apparecchio per reggiare con reggetta di plastica



Vor dem Gebrauch des Gerätes die Betriebsanleitung aufmerksam lesen.

Before using the tool, read the operating instructions carefully.

Avant l'utilisation de l'appareil, consultez soigneusement le mode d'emploi.

Prima d'utilizzare l'apparecchio, leggere attentamente le istruzioni per l'uso.



TABLE OF CONTENTS

	Page
1 Technical data	14
2 General information	15
2.1 Information on environmental protection	15
3 Safety instructions	16
3.1 Safety instructions for battery charger and battery	16
4 Description	17
4.1 Design	17
4.2 Battery charger indicators	17
5 Initial operation	18
5.1 Battery charger	18
5.2 First battery charge	18
5.3 Charging the battery	18
6 Operating instructions	19
6.1 Operating the tool	19
7 Preventive and corrective maintenance	22
7.1 Changing the battery	22
7.2 Adjusting welding time	22
7.3 Adjusting strap tension	23
7.4 Adjusting strap width	23
7.5 Cleaning the tool	24
7.6 Changing the tension wheel	24
7.7 Changing the tension shoe	24
8 Recommended spare parts	47
8.1 Parts list	47
Explosion drawing	53

1

TECHNICAL DATA

Weight	4 kg (8.8 lbs.)
Dimensions	Length 400 mm (15.75") Width 130 mm (5") Height 200 mm (7.90")
Strap tension	With friction clutch fully variable up to 2300 N (510 lbs.) depending on strap quality
Sealing	Friction welded
Voltage	Battery charger 230 V (115 V) Battery 12 V
Emission sound pressure levels, measurement type A (EN ISO 11202)	L_{pA} 83 dB (A)
Vibrations at handle (EN ISO 8662-1)	$a_{h,w}$ 7,3 ms ⁻²
PLASTIC STRAP	
Strap quality	Polypropylene (PP) Polyester (PET)
Strap width	9–10, 12–13, 15–16 or 19 mm ($\frac{3}{8}$ " , $\frac{1}{2}$ " , $\frac{5}{8}$ " or $\frac{3}{4}$ ")
Strap thickness	0.5–1.0 mm (.019"–.039")

DECLARATION OF AGREEMENT

We take sole responsibility for declaring that the tool OR-T 50, to which this declaration refers, is in full compliance with the current requirements of the guidelines laid down by the council on 22th June 1998 (98/37/ECC), "Machine Guidelines".

Furthermore, electrical installations are in compliance with the guideline laid down by the council on 19. February 1973 (73/23/EEC) "Low Voltage Guidelines" and from 3th May 1989 (89/336/EEC) "EMV Guidelines".

According to norm:
EN ISO 12100-1, EN ISO 12100-2, EN 349, EN 1050, EN 61000-6-1, EN 61000-6-3
CH-8953 Dietikon, 02.11.2005

Sales Manager General Manager Products
Packaging Technology: Packaging Technology:



R. Kieffer

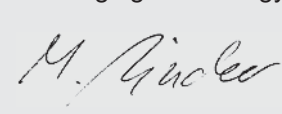

M. Binder

2

GENERAL INFORMATION

These operating instructions are intended to simplify familiarisation with the strapping tool and its proper use for the intended purpose. The operating instructions contain important information concerning the safe, proper and efficient use of the strapping tool. Compliance with the instructions will help to avoid danger, reduce repairs and stoppages and increase the reliability and service life of the strapping tool.

The operating instructions must always be available at the place of operation of the strapping tool. They must be read and observed by all persons concerned with work on the strapping tool. This work specifically includes operation, refilling of operating material, fault elimination and maintenance.

In addition to the operating instructions and the regulations for accident prevention effective in the country of use and place of application, the recognised technical regulations for safety and proper operation must also be observed.



CAUTION!

Used where there is danger to life and health.



WARNING!

Used for danger which can cause material damage.

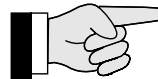

NOTE!

Used for general information and information which, if not followed can cause faults in the operating sequence.

2.1 INFORMATION ON ENVIRONMENTAL PROTECTION

This tool is manufactured without any physical or chemical substances which could be dangerous to health.

For disposal of all the parts, the governmental instructions must be observed. The electrical assemblies should be dismantled so that the mechanical, electro-mechanical and electronic components can be disposed of separately.

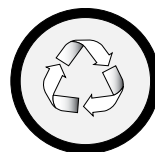

Dealers provide an environmentally-friendly battery disposal service

- Do not open the battery.
- Do not throw the used battery into household waste, fire or water.

Defective or used batteries undergo a complete recycling process.

3

SAFETY INSTRUCTIONS



Inform yourself!
Read the operating instructions carefully. Preventive and corrective maintenance on the tool may only be carried out by trained personnel.



Original ORGAPACK spare parts must be used exclusively!
Not using original spare parts will dissolve the warranty and the liability.



Protect yourself!
When operating the tool, wear eye, face and hand protection (cut-proof gloves).

Use for the intended purpose

This tool is designed for strapping packages, pallet loads and the like.

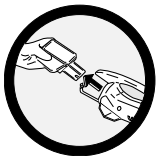

Power source!
Before starting preventive or corrective maintenance, remove battery from the tool.

The tool was designed and manufactured to provide safe handling during the strapping operation.

The tool is designed for use with plastic straps (polypropylene and polyester).



Warning:
Strap will snap forward!
When cutting the strap, hold the upper portion and stand safely away from the strap.
Caution:
The lower strap will snap forward.

Possible misuse

The use of steel straps is not possible.

3.1 SAFETY INSTRUCTIONS FOR BATTERY CHARGER AND BATTERY



Warning:
Strap could break!
Do not stand in line with the strap while it is tensioned. The strap could break!



Always inspect the electrical plug and cable before use. If damaged, they must be replaced by qualified personnel.



Caution:
Only strap packed goods!
Do not put hands or other parts of the body between the strap and the package during the strapping process.

- Do not charge other types of batteries (see chapter 5.1) and use original accessories only.
- Keep the battery charger slot free of foreign objects and protect against dirt.
- Protect the battery charger against humidity and use it in dry areas only.
- Do not open the battery. Protect the battery against impact, heat and fire. Risk of explosion!
- When the battery is outside the battery charger, cover its battery terminals to avoid short circuits with metal objects. Risk of fire and explosion!
- Keep battery dry and protected against frost. Do not store it at temperatures over 50°C or below 10°C.
- Damaged batteries should not be used longer.



Caution:
Danger of squeezing!
Do not put your fingers into the tension wheel area.



Do not use water!
Do not use water or steam to clean the tool.

4

DESCRIPTION

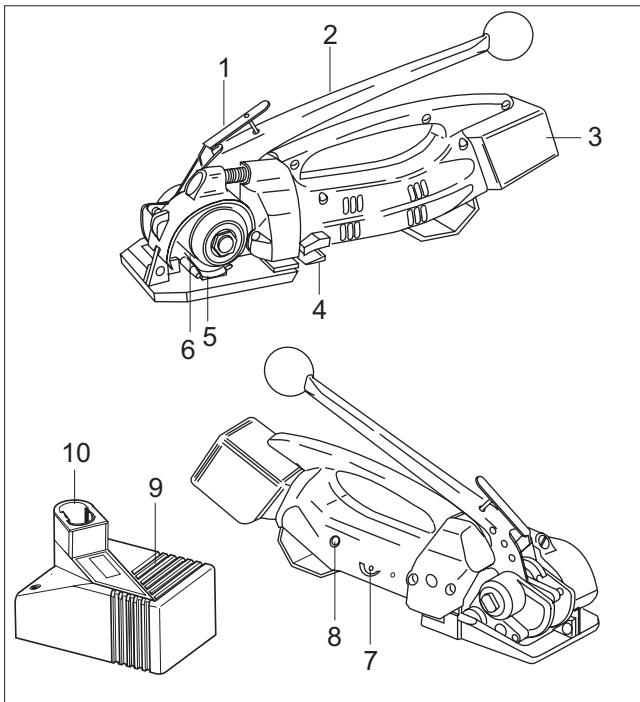

Fig. 1

4.1 DESIGN

- 1 Welding lever
- 2 Tension lever
- 3 Battery
- 4 Cutting device
- 5 Tension shoe
- 6 Tension wheel
- 7 Potentiometer „Welding time“
- 8 Indicator „Battery“
- 9 Battery charger
- 10 Adapter

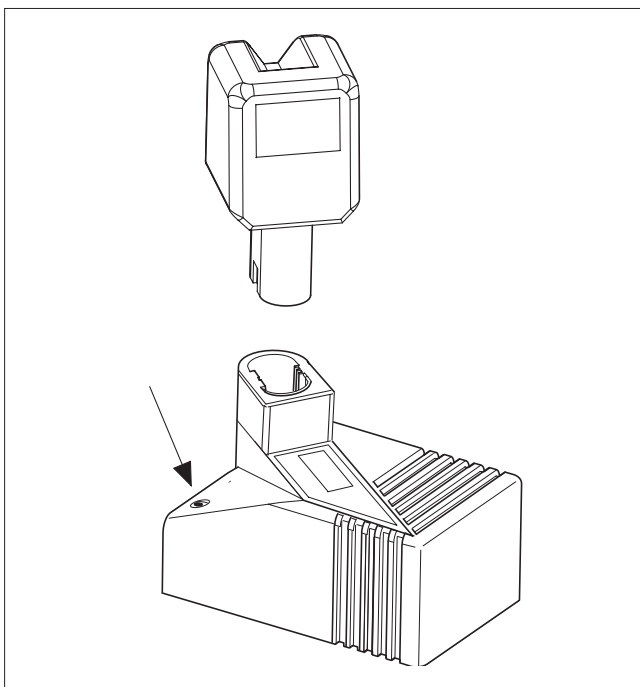



Fig. 2

4.2 BATTERY CHARGER INDICATORS

Continuous light 

Ready for charging

Battery not inserted:
Main voltage is on.

Flashing light 

Rapid charging

Rapid charging operates until the battery is fully recharged. The battery charger automatically switches to trickle- and trickle charging.

Continuous light 

Trickle charging

Battery inserted: The battery charger is only delivering a trickle charge because the battery is already fully charged.

Double flashing 

Temperature

Warning: The battery is too hot (or too cold). Trickle charging only. The battery charger automatically switches to rapid charging when the temperature is in the permitted range again.

Quick flashing 

Error message

Warning: Battery can not be charged (battery defective or battery charger slot dirty).

 For detailed information, refer to operating instructions for the battery charger.

5

INITIAL OPERATION

5.1 BATTERY CHARGER

230 V (115 V) battery chargers can be operated at 220 V or 240 V (110 V).

The battery charger is suitable only for charging (NiCd/NiMH) batteries (voltage between 7.2 V and 14.4 V).

AL 60 DV 1419
7.2 V - 14.4 V

Fig. 3

5.2 FIRST BATTERY CHARGE

 Please note the following points in order to obtain optimum battery life:

- Connect battery charger (4/3) to mains voltage.
- Insert adapter (4/2) into battery charger slot.
- Insert battery (4/1) into battery charger.

For the first charge, leave the battery in the charger for at least five hours, regardless of the battery indicator. (The charging time for all subsequent charges is about 60 minutes)

For all subsequent charges, only recharge the battery when the red indicator light on the tool comes on (see section 7.1). Avoid constant charging when the battery is not yet discharged. This will ensure optimum battery capacity and life.

Maximum battery output will be reached after four or five charging/discharging cycles.

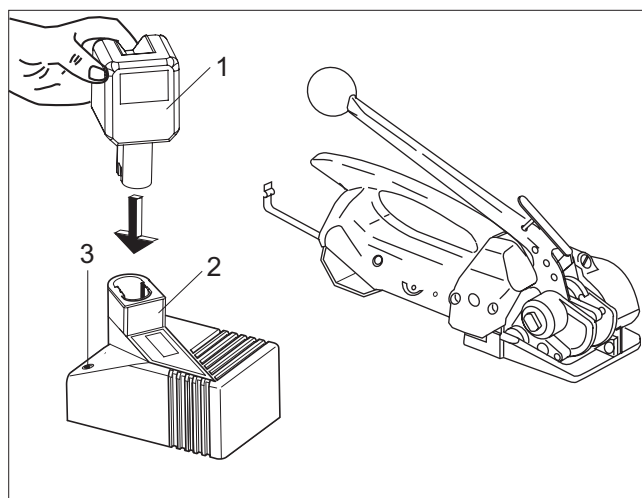



Fig. 4

5.3 CHARGING THE BATTERY

The charging process and error functions are indicated by a green light (4/3), see chapter 4.2.

The charging time is approx. 60 min.

The maximum charging current flows when the temperature of the battery is between 15–45°C. Avoid charging at battery temperatures below 0°C.

 If the battery is not to be used for a longer period (several days), it should be removed from the tool and charged in the battery charger.

The intelligent charger with fuzzy control charges the battery with the optimum rapid charging current, depending on temperature and capacity. If fully charged, a preserving charge will prevent self-discharge and thus guarantee a long battery life.

6

OPERATING INSTRUCTIONS

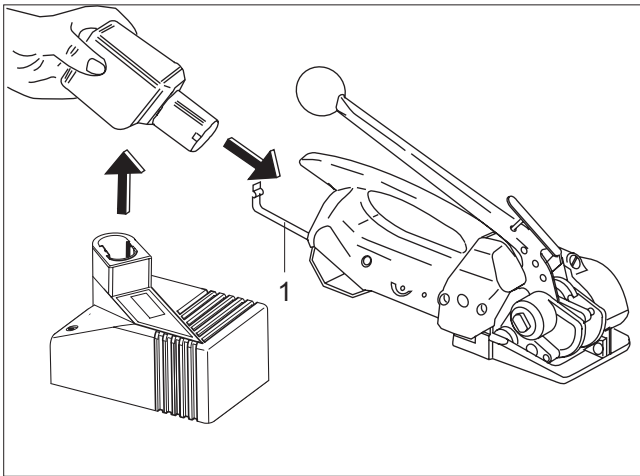

Fig. 5

6.1 OPERATING THE TOOL

- Insert charged battery and close the bow spring (5/1).

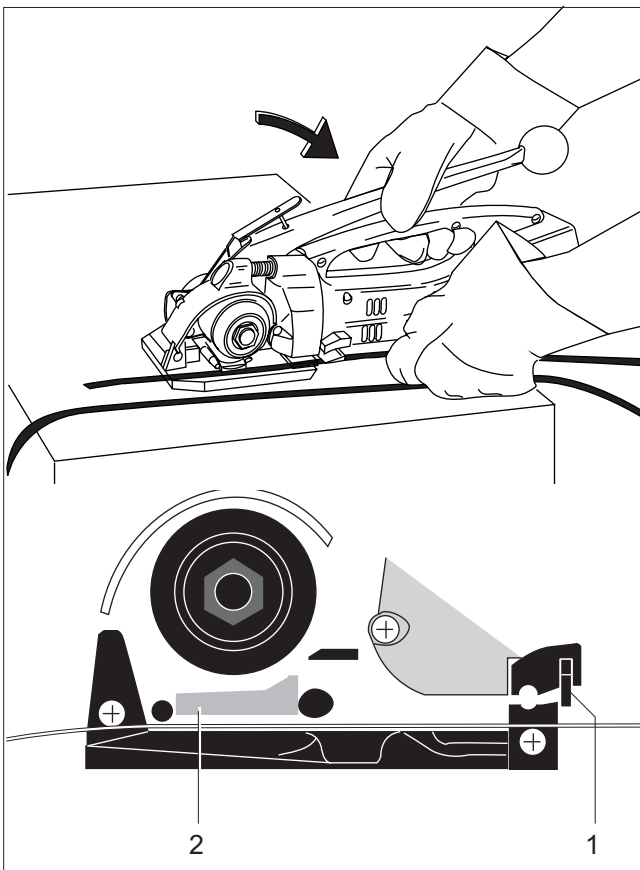

Fig. 6

- Place the strap around the package and hold it with the left hand so that the lower strap lead is approx. 20 cm (8") away from the hand.
- Take the tool with the right hand and press the lever towards the handle.
- Slide the strap lead under the tension shoe (6/2) and under the cutting device (6/1) into the tool until the stop is reached.



The lower strap is now approx. 5 cm (2") beyond the tool.

- Release the lever.

- Insert the strap from coil holder between the tension wheel (7/3) and the tension shoe (7/2). Then insert the strap into the slot of the cutting device (7/1) until stop is reached.

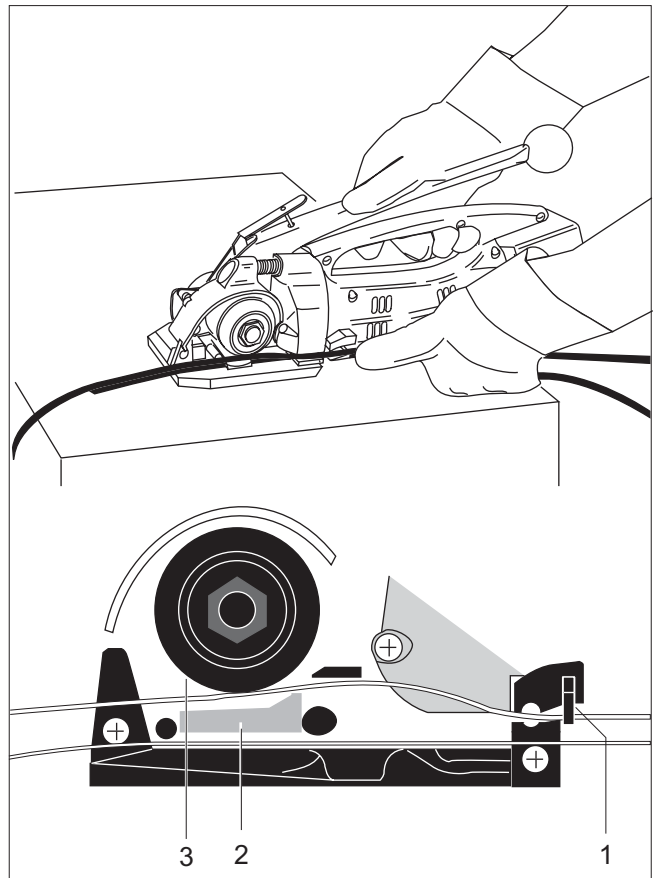

Fig. 7

- Hold the tool by the grip with the left hand and move the tension lever with the right hand back and forward until the desired strap tension is reached.



The maximal strap tension is adjustable (see chapter 7.3).

If the tool is used in a dusty environment, it is recommended to clean the tool regularly. The tension wheel in particular should be kept clean (see chapter 7.5).

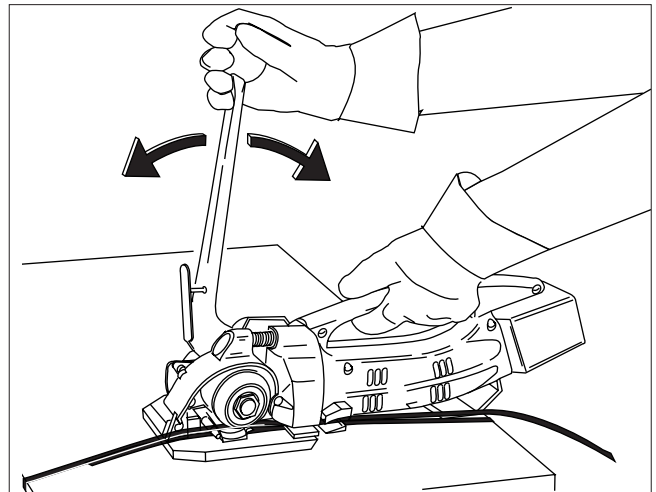

Fig. 8

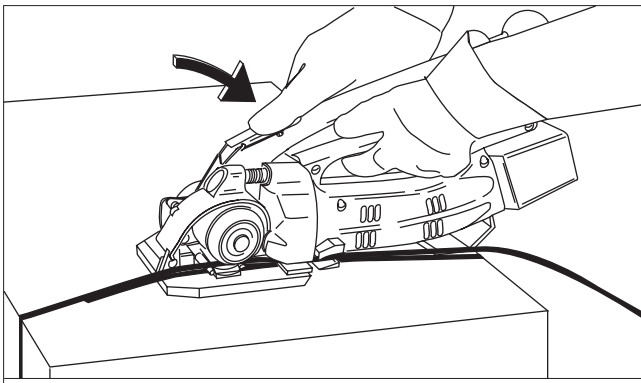
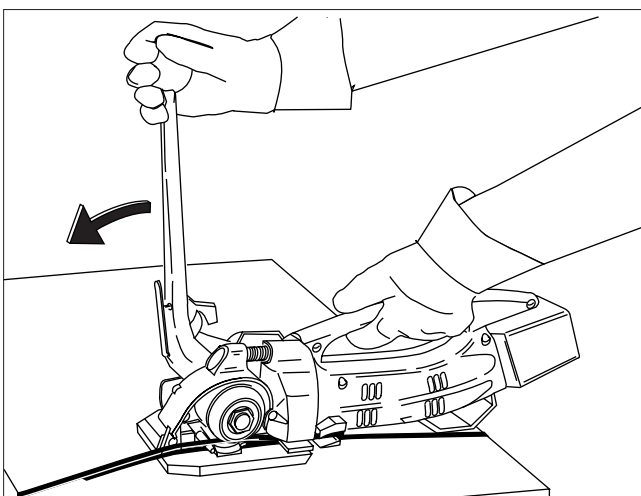



Fig. 9

- Bring back the tension lever to the intermediate position, push the yellow welding lever towards the tension lever. Now the tool is ready for sealing the straps.



- Push lever to stop (sealing position). The left hand remains on the handle of the tool to bear the counterforce.

 The straps are welded together and the upper strap is cut off.

- Hold lever in this position (approx. 2 sec.) until signal lamp (12/1) is switched off.



Green flashing

If the LED flashes green the cooling time is running.



Continuous red light

When the red light is on continuously, the battery must be charged (see chapter 5.2).

-  When the red signal lamp lights up, no welding is performed, since the remaining charge in the battery is insufficient to ensure proper welding of the straps.



LED-Status	Function
Led light off	Battery fully charged
 orange	approx. 40% residual capacity
 red	battery empty
 green	cooling time

Fig. 10

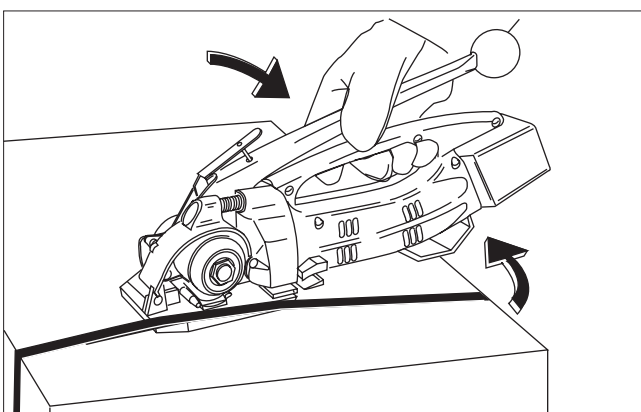

Fig. 11

- Press lever against the handle. Then swing the tool away from the strapping to the right at the rear.
- Check the seal (refer to chapter 7.2).

7

PREVENTIVE AND CORRECTIVE MAINTENANCE

7.1 CHANGING THE BATTERY



Continuous red light

If the red signal lamp (12/1) is lit continuously, the battery must be charged (see chapter 5.2).

- Open bow spring and remove discharged battery.
- Insert charged battery and lock with bow spring.

 When changing the battery, the new battery must only be inserted after approx. five seconds to ensure that the electronic system can reset to the initial position. If the battery change is too rapid, the red signal lamp lights up and the unit remains blocked.

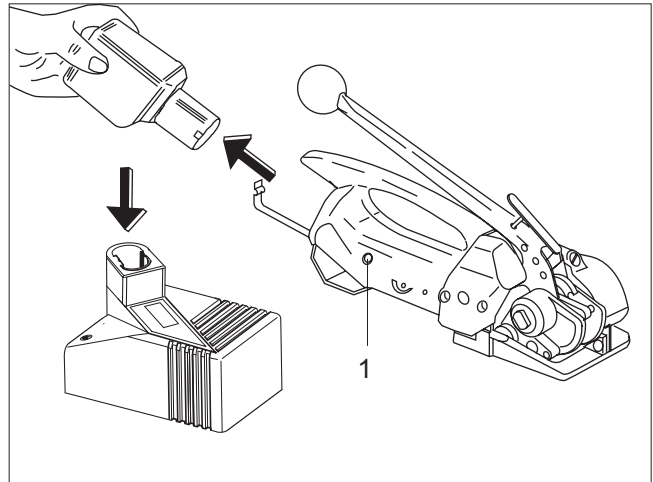

Fig. 12

7.2 ADJUSTING WELDING TIME

- The welding time can be infinitely adjusted with a screwdriver (no 1), depending on strap quality and dimension.
- By turning the screw carefully clockwise, the welding time will be longer, by turning counterclockwise it will be shorter.



The printed circuit board could be damaged if the screw is turned too far either clockwise or anticlockwise.

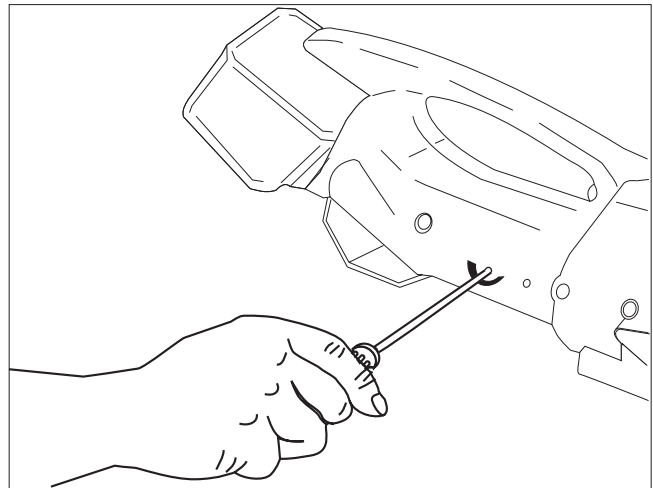

Fig. 13



Check appearance of seal (see fig. 14) regularly.

- 1 **Good seal** (the complete surface is cleanly welded without excess material being forced out sideways).
- 2 **Poorly welded seal** (not welded over the complete surface), welding time too short.
- 3 **Poorly welded seal** (excess material is forced out sideways), welding time too long.



An incorrectly welded strapping cannot secure the package and can thus lead to injuries.

Never transport or move packaged goods with incorrectly welded seals.

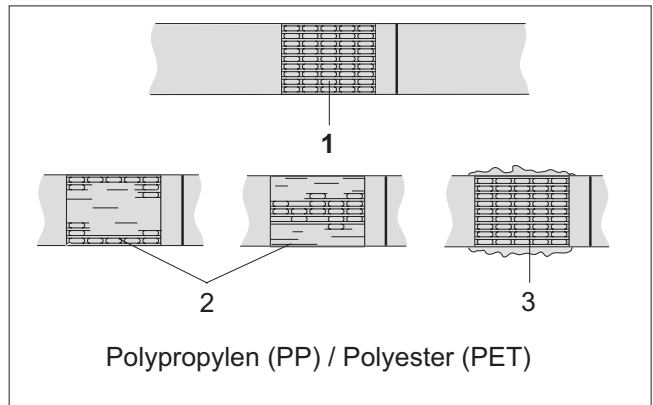

Fig. 14

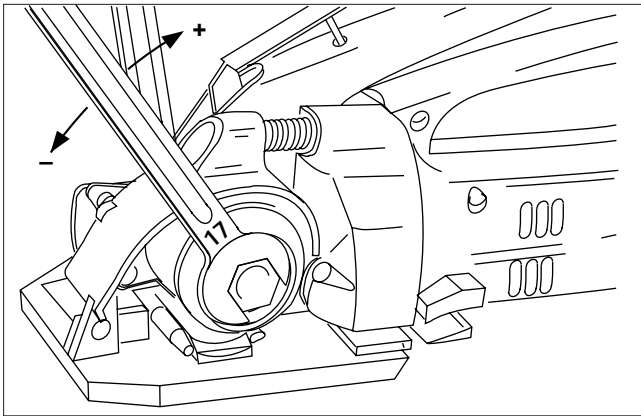



Fig. 15

7.3 ADJUSTING STRAP TENSION

 The maximum strap tension is determined by the adjustment of the friction clutch. For this reason two fork wrenches are supplied.

- Block the tension shaft with the small fork wrench (SW 11).
- With the other fork wrench (SW 17) adjust the nut.
- Turning the nut in clockwise direction the strap tension is increased.
- Turning the nut in counterclockwise direction the strap tension is reduced.

 Best results are achieved by adjusting the clutch to the maximum tension for the package being strapped. But not as tight that the tension wheel will turn over or the strap breaks.

7.4 ADJUSTING STRAP WIDTH

- To change the strap width, the strap stop (16/2) must be removed with the screw (16/1) from the tool and refitted with washers (1.5 mm thick) according to the width of the strap.
- Strap width 19 mm ($\frac{3}{4}$ ") one washer
- Strap width 15–16 mm ($\frac{5}{8}$ ") one washer
- Strap width 12–13 mm ($\frac{1}{2}$ ") two washers
- Strap width 9–10 mm ($\frac{3}{8}$ ") three washers

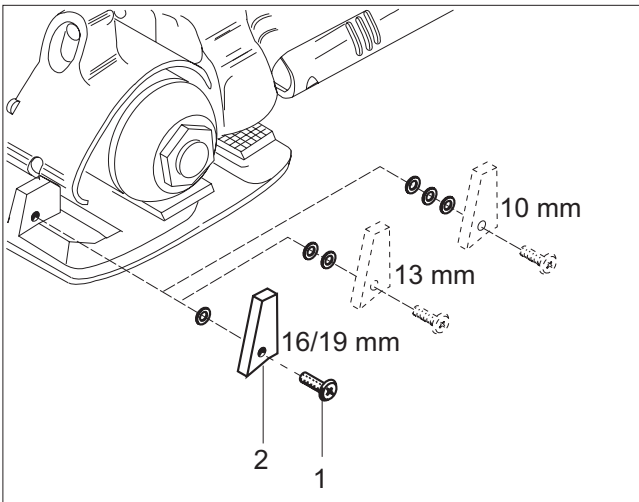

Fig. 16

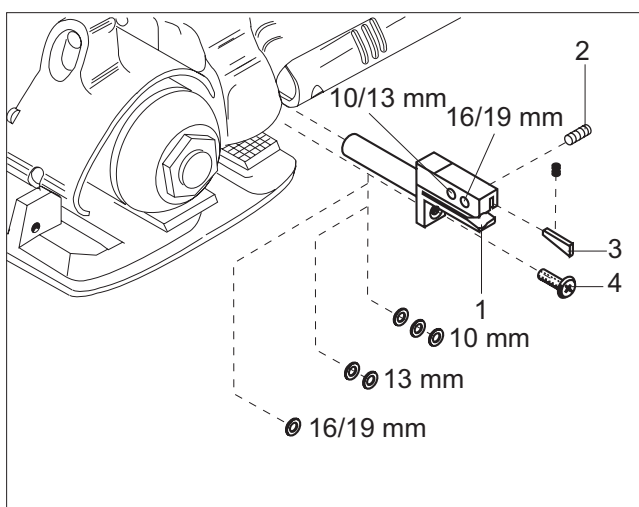



Fig. 17

- Loosen screw (17/4) and remove knife bushing (17/1).
- Remove pin screw (17/2) and move the pawl (17/3) to desired position according to strap width. Tighten pin screw (17/2)
- Insert washers between base plate and knife bushing according to strap width.
- Tighten screw (17/4).
- Strap width 19 mm ($\frac{3}{4}$ ") one washer
- Strap width 15–16 mm ($\frac{5}{8}$ ") one washer
- Strap width 12–13 mm ($\frac{1}{2}$ ") two washers
- Strap width 9–10 mm ($\frac{3}{8}$ ") three washers

7.5 CLEANING THE TOOL

 If the tool is used in a dusty environment, it is recommended to clean the tool regularly. The tension wheel (18/1) in particular should be kept clean.

- Clean the tension wheel with the steel brush supplied with the tool.

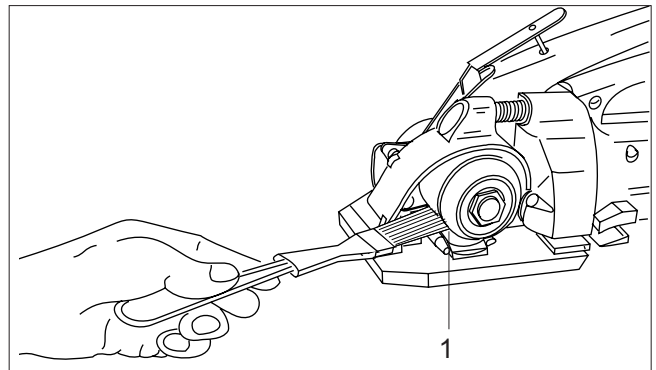

Fig. 18

7.6 CHANGING THE TENSION WHEEL

Removal

- Open bow spring (19/2) and remove battery (19/1).
- Block the tension shaft (19/9) with the small fork wrench (SW 11).
- With the other fork wrench (SW 17) loosen the nut.
- Remove five spring washers (19/4) and carrier (19/3).
- Press tension lever and remove pin (19/10).
- Remove tension wheel (19/7) together with the clutch disks (19/6) and (19/8).
- Check clutch disks for wear, if necessary replace it. Replace tension wheel.

Installation

- Install the parts in reverse order.

 Do not lubricate the clutch disks. Adjust the maximum tension force (see chapter 7.3).

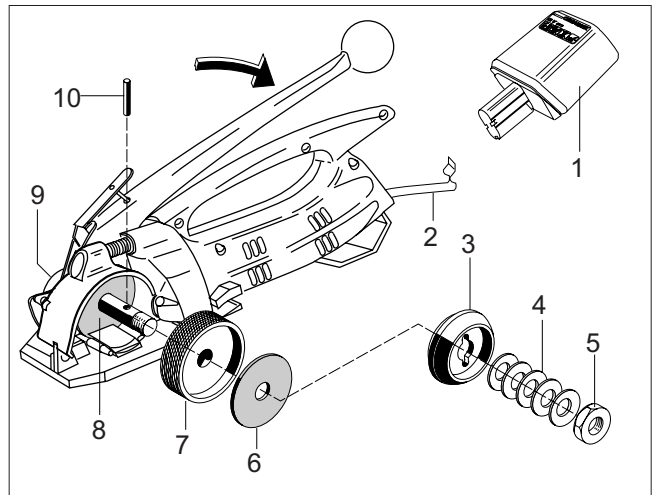

Fig. 19

7.7 CHANGING THE TENSION SHOE

Removal

- Open bow spring (20/2) and remove battery (20/1).
- Push the tension lever forward until the stop is reached.
- Remove set screw (20/5) with compression spring (20/6) and bolt (20/7).
- Release set screw (20/9).
- Push out shaft (20/8) with a small screwdriver.
- Raise rocker unit (20/10) and remove and replace tension shoe (20/3).
- Clean tooth plates and tension wheel.

Installation

- Install the parts in reverse order.

 Before inserting the rocker unit (20/10) lift stroke lever (20/4) that the switch link of the rocker lies below the stroke lever. After mounting the shaft turn the tension wheel until the rocker moves down. Screw in set screw (20/9) until it is in line with the casing.

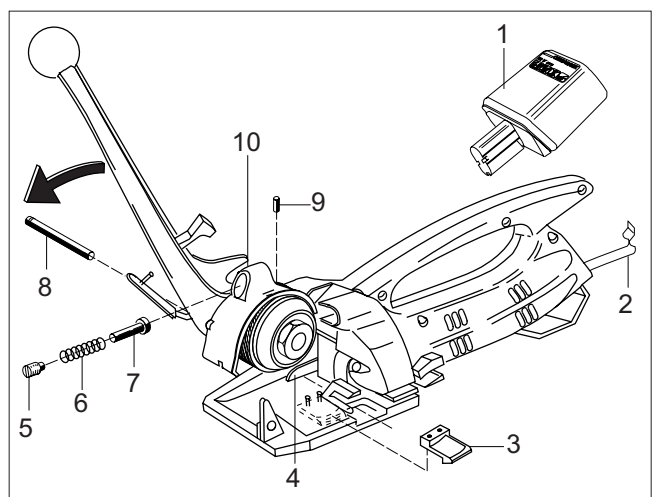

Fig. 20

8

Empfohlene Ersatzteile

Recommended spare parts

Pièces de rechange recommandées

Parti di ricambio consigliate

Bei Bestellungen immer Artikel-Nr. angeben

When ordering please indicate part number

Lors d'une commande, veuillez indiquer le numéro d'article

Nelle ordinazioni indicare sempre il numero dell'articolo

Pos.	Artikel-Nr. Part no No d'article Art. nr.	Benennung Part name	Article	Articolo	Stück Quantity Pièce Pezzi
39	1821.048.002	Zahnplatte	Plaque dentée	Piastra dentata	2
41	1821.048.004	Spannschuh	Plaque de tension	Scarpina per tensione	1
87	1821.047.003	Spannrad	Mollette de tension	Rotella di tensione	1
89	1830.000.262	Kupplungsscheibe	Disque d'embrayage	Disco frizione	2
126	1821.020.042	Scheibe	Rondelle	Rondella	6
129	1911.804.127	Senkschraube, M 4 x 12	Vis noyée	Vite a testa svasata	2

8.1 Teilleiste 1832.002.020/1.4

8.1 Parts list

8.1 Liste des pièces

8.1 Lista delle parti

Bei Bestellungen immer Artikel-Nr. angeben

When ordering please indicate part number

Lors d'une commande, veuillez indiquer le numéro d'article

Nelle ordinazioni indicare sempre il numero dell'articolo

1	1832.011.146	Grundplatte, inkl. Pos. 2-4	Plaque de base, incl. pos. 2-4	Piastra di base, incl. pos. 2-4	1
2	1935.506.100	Radial-Gleitlager, ø 6/8 x 10	Palier lisse	Bronzina radiale	2
3	1935.506.060	Radial-Gleitlager, ø 6/8 x 6	Palier lisse	Bronzina radiale	1
4	1922.104.123	Passkerbstift, ø 4 x 12	Goupille cannelée	Spina scanalata	2
5	1933.906.090	Nadelbüchse, ø 6/10 x 9	Palier à aiguille	Bussola ad aghi	1
6					
7	1910.604.082	Gewindestift, M 4 x 8	Goujon fileté	Perno filettato	1
8	1832.011.153	Gehäuseschalen Set, inkl. Pos. 9	Pièces du bâti, incl. pos. 9	Involucri, incl. pos. 9	1
9	1960.000.599	Deckel, ø 10	Couvercle,	Coperchio	1
10					
11	1832.011.027	Abdeckung	Couvercle,	Copertura	1
12	1821.019.001	Bügfeder	Ressort	Molla	1
13					
14					
15	1914.635.160	PT-Schraube, KA 35 x 16	Vis PT	Vite PT	6
16	1914.635.300	PT-Schraube, KA 35 x 30	Vis PT	Vite PT	2
17	1914.404.128	Linsenschraube, M 4 x 12	Vis à tête	Vite a testa svasata	4
18	1821.033.009	Bolzen	Goujon	Albero	1
19					
20	1832.031.001	Wippe rechts, inkl. Pos. 21	Bascule de droite, incl. pos. 21	Bilanciere a destra, incl. pos. 21	1

Pos.	Artikel-Nr. Part no No d'article Art. nr.	Benennung	Part name	Article	Articolo	Stück Quantity Pièce Pezzi
21	1935.508.120	Radial-Gleitlager, ø 8/10 x 12	Slide bearing	Palier lisse	Bronzina radiale	3
22	1926.502.160	Hülsenfreilauf, ø 16/22 x 26	Bearing	Roulement	Ruota libera	1
23	1911.803.128	Senkschraube, M3 x 12	Counter sunk screw	Vis noyée	Vite	1
24	1911.006.208	Zylinderschraube, M 6 x 20	Cylinder screw	Vis cylindrique	Vite cilindrica	1
25	1919.606.072	Sicherungsscheibe, M 6	Lock washer	Rondelle de sécurité	Ranella di sicurezza	1
26	1921.405.451	Spiralstift, ø 5 x 45	Spiral pin	Goupille élastique	Coppiglia elastica	1
27						
28						
29	1832.031.041	Wippe links, inkl. Pos.4,21,26,32,36	Rocker left	Bascule gauche	Bilanciere a sinistra	1
30						
31						
32	1921.406.201	Spiralstift, ø 6 x 20	Spiral pin	Goujon	Coppiglia elastica	2
33	1832.031.011	Finger	Bolt	Goujon	Perno	1
34	1821.010.018	Druckfeder	Compression spring	Ressort de compression	Molla a pressione	1
35	1820.030.092	Gewindestift	Set screw	Goujon fileté	Perno filettato	1
36	1933.716.160	Nadelhülse, ø 16/22 x 16	Needle bushing	Palier à aiguille	Bussola ad aghi	1
37	1821.039.006	Bolzen	Bolt	Goujon	Spinello	1
38						
39	1821.048.002	Zahnplatte	Tooth plate	Plaque dentée	Piastra dentata	2
40	1821.205.014	Distanzplatte	Spacer plate	Plaque d'écartement	Distanziatore	1
41	1821.048.004	Spannschuh	Tension plate	Plaque de tension	Scarpina per tensione	1
42						
43	1832.041.004	Anschlag	Stop	Butée	Battuta	1
44	1921.404.261	Spiralstift, ø 4 x 26	Spiral pin	Goupille élastique	Spina elastica	2
45						
46						
47	1832.022.002	Schweiss Schuh	Welding shoe	Plaque de soudure	Piastra di saldatura	1
48	1821.033.007	Bolzen	Bolt	Goujon	Spinotto	1
49	1923.501.120	Splint, ø 2 x 12	Cotter pin	Goupille fendue	Coppiglia	1
50	1832.022.123	Zahnplatte	Tooth plate1	Plaque dentée	Piastra dentata	
51						
52						
53						
54	1933.706.090	Nadelhülse, ø 6/10 x 9	Needle bushing	Palier à aiguille	Bussola ad aghi	1
55	1832.033.006	Exzenterwelle	Eccentric shaft	Arbre excentrique	Albero eccentrico	1
56	1917.401.065	Distanzscheibe, ø 6/18 x 0,5	Spacer disk	Disque d'écartement	Rondella distanziatrice	4
57	1832.011.022	Flansch	Flange	Bride	Flangia	1
58	1911.004.128	Zylinderschraube, M 4 x 12	Cylinder screw	Vis cylindrique	Vite cilindrica	3

Pos.	Artikel-Nr. Part no No d'article Art. nr.	Benennung	Part name	Article	Articolo	Stück Quantity Pièce Pezzi
59	1911.004.088	Zylinderschraube, M 4 x 8	Cylinder screw	Vis cylindrique	Vite cilindrica	2
60	1821.250.003	Präzisions-Wellenkupplung, inkl. Pos. 61	Coupling, incl. pos. 61	Accouplement, incl. pos. 61	Giunto, incl. pos. 61	1
61	1910.703.062	Gewindestift, M 3 x 6	Set screw	Goujon fileté	Perno filettato	4
62						
63	1933.710.150	Nadelhülse, ø 10/14 x 15	Needle bushing	Douille d'aiguille	Bussola ad aghi	1
64	1821.140.002	Motor	Motor	Moteur	Motore	1
65	1832.022.001	Pleuel	Connecting rod	Bielle	Biella	1
66	1821.205.013	Lasche	Link	Eclisse	Giunto	1
67	1821.031.015	Bolzen	Bolt	Goujon	Spinotto	2
68	1920.103.062	Sicherungsscheibe, ø 3,2	Lock washer	Rondelle de sécurité	Anello di sicurezza	4
69						
70	1832.022.006	Druckhebel	Pressure piece	Levier	Leva a pressione	1
71						
72						
73	1832.022.004	Hubplatte	Stroke piece	Élévateur	Piastra elevatrice	1
74	1821.020.039	Druckrolle	Press roll	Galet de pression	Rullo di pressione	1
75	1821.030.014	Bolzen	Bolt	Goujon	Spinotto	1
76	1821.039.008	Gewindestift	Set screw	Goupille fileté	Perno esagonale	1
77	1821.011.003	Zugfeder	Tension spring	Ressort à tension	Molla di torsione	1
78	1821.019.003	Tellerfeder, ø 18/8,2 x 1	Saucer spring	Rondelle bombée	Ranella a tazza	9
79	1821.031.016	Bolzen	Bolt	Goujon	Spinotto	1
80	1920.105.072	Sicherungsscheibe, ø 5	Lock washer	Rondelle de sécurité	Anello di sicurezza	9
81						
82						
83	1832.033.005	Spannwelle	Tension shaft	Arbre de tension	Albero di tensione	1
84	1830.000.062	Scheibenfeder	Key	Coin	Ranella	1
85	1821.030.024	Stift	Pin	Goupille	Spina	2
86	1821.255.002	Mitnehmerscheibe	Carring disc	Disque entraîneur	Disco di trascinamento	1
87	1821.047.003	Spannrad	Tension wheel	Molette de tension	Rotella di tensione	1
88	1821.255.001	Mitnehmer	Carrier	Entraîneur	Trascinatore	1
89	1830.000.262	Kupplungsscheibe	Clutch disc	Disque d'embrayage	Disco frizione	2
90	1925.210.122	Tellerfeder, ø 25/12,2 x 1,5	Saucer spring	Rondelle bombée	Ranella a tazza	5
91	1820.020.163	Mutter	Nut	Ecrou	Dado	1
92	1832.039.007	Ring	Ring	Anneau	Anello	1
93						
94	1820.010.182	Zugfeder	Tension spring	Ressort de traction	Molla di tensione	1
95						

Pos.	Artikel-Nr. Part no No d'article Art. nr.	Benennung	Part name	Article	Articolo	Stück Quantity Pièce Pezzi
96						
97	1930.180.356	Rillenkugellager	Bearing	Roulement à billes	Cuscinetto	1
98	1821.020.037	Büchse	Bushing	Douille	Bussola	1
99						
100	1821.080.003	Spannhebel komplett, inkl. Pos. 102	Tension lever complete, incl. pos. 102	Levier de tension complet,incl. pos. 102	Leva di tensione completa, incl. pos. 102	1
101						
102	1820.080.051	Kugelgriff	Knob	Poignée sphérique	Pomolo	1
103						
104	1832.039.008	Klinke	Pawl	Cliquet	Leva	1
105	1832.039.009	Klinke	Pawl	Cliquet	Leva	1
106	1820.010.149	Drehfeder	Torsion spring	Ressort de combiné	Molla di torsione	1
107	1821.031.013	Bolzen	Bolt	Goujon	Spinotto	2
108						
109						
110						
111	1821.084.002	Schweisstaste	Welding lever	Levier de soudure	Leva di saldatura	1
112	1821.012.007	Drehfeder	Torsion spring	Ressort de torsion	Molla di torsione	1
113	1821.031.014	Bolzen	Bolt	Goujon	Spinotto	1
114	1820.040.060	Sperrad	Locking wheel	Roue à rochet	Rondella d'arresto	1
115	1821.089.005	Schaltiasche komplett	Switch link complete	Eclisse d'entraînement complète	Linguetta completa	1
116						
117						
118						
119						
120						
121	1917.401.165	Distanzscheibe, ø 16/28 x 0,5	Spacer disk	Disque d'écartement	Rondella distanziatrice	3
122	1920.112.132	Sicherungsscheibe, ø 12	Lock washer	Rondelle de sécurité	Anello di sicurezza	1
123						
124						
125	1832.041.002	Bandführung	Strap guide	Guidage pour bande	Guida reggetta	1
126	1821.020.042	Scheibe	Washer	Rondelle	Rondella	4
127						
128						
129	1911.804.127	Senkschraube, M 4 x 12	Counter sunk screw	Vis noyée	Vite a testa svasata	2
130						
131	1821.209.003	Messerröhse	Knife sleeve	Douille de couteau	Bussola coltello	1
132	1832.042.035	Klinke	Pawl	Cliquet	Leva	1
133	1820.030.418	Spez. Schraube	Special screw	Vis spéciale	Vite speciale	1

Pos.	Artikel-Nr. Part no No d'article Art. nr.	Benennung Part name	Article	Articolo	Stück Quantity Pièce Pezzi
134	1821.010.019	Druckfeder	Compression spring	Ressort de compression	Molla di pressione
135					1
136	1821.209.016	Abschneidmesser komplett	Knife complete	Couteau complète	Coltello completa
137					1
138	1821.012.008	Drehfeder	Torsion spring	Ressort de torsion	Molla di torsione
139					1
140					
141	1832.022.007	Hubhebel	Stroke lever	Levier élévateur	Leva di sollevamento
142	1821.020.040	Büchse	Bushing	Douille	Bussola
143	1821.030.013	Bolzen	Bolt	Goujon	Spinotto
144	1821.039.005	Bolzen	Bolt	Goujon	Spinotto
145					1
146					
147					
148					
149					
150	1821.152.007	Steuerprint	Printed circuit board	Carte circuit imprimé	Circuito stampato
151					1
152					
153	1914.630.100	PT-Schraube, KA 30 x 10	PT-Screw	Vis PT	Vite PT
154					4
155	2179.110	Akku, 12 V, inkl. Pos. 156	Battery, 12 V, incl. pos. 156	Accumulateur, 12 V, incl. pos. 156	Accumulatore, 12 V, incl. pos. 156
156	1821.090.012	Firmenschild "Akku"	Name tag "Battery"	Plaque „Accumulateur“	Targhetta „accumulatore“
157	2179.220	Set Ladegerät/Adapter, 230 V, EU	Charger/adapter set, 230 V EU	Jeu de chargeur/adapter, 230 V, EU	Serie caricatore/adattore, 230 V
158					1
159	2179.221	Set Ladegerät/Adapter, 115 V, USA	Charger/adapter set, 115 V USA	Jeu de chargeur/adapter, 115 V, USA	Serie caricatore/adattore, 115 V, USA
160	2179.222	Set Ladegerät/Adapter, 100 V, Japan	Charger/adapter set, 100 V Japan	Jeu de chargeur/adapter, 100 V, JP	Serie caricatore/adattore, 100 V, Japan
161	2179.115	Adapter	Adapter	Adaptateur	Adattore
162					1
163	1821.090.021	Firmenschild "Ladegerät"	Name tag "Battery charger"	Plaque „Chargeur pour accumulateur“	Targhetta „caricatore“
164	1821.091.039	Typenschild	Type plate	Plaque de type	Placchetta de tipo
165					1
166					
167	1832.011.078	Einlage kurz	Insert short	Entretoise court	Supporto anteriore corto
168	1832.011.079	Einlage lang	Insert long	Entretoise long	Supporto anteriore lungo
169					1
170	1821.092.016	Hinweisschild "CE"	Indication plate "CE"	Plaque indicatrice "CE"	Targhetta "CE"
171	1821.092.017	Hinweisschild "4"	Indication plate "4"	Plaque indicatrice "4"	Targhetta "4"

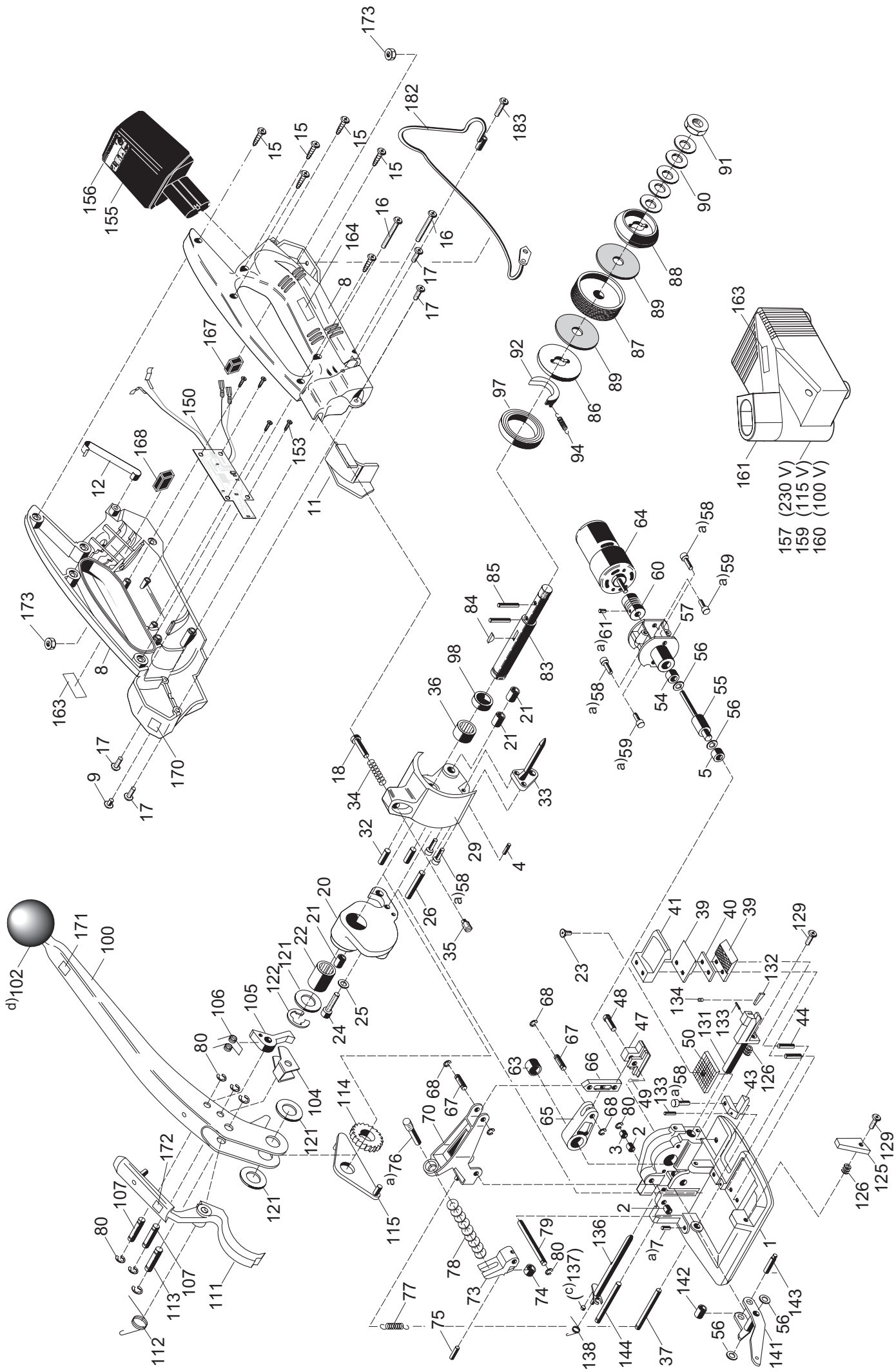

a) Loctite 222 c) Loctite 406 d) Loctite 480

OR-T 50 1832.002.020/1

20.09.05 nm/hp
12.06/WE